

Gernot Hoffmann

...What is Computer Vision ?

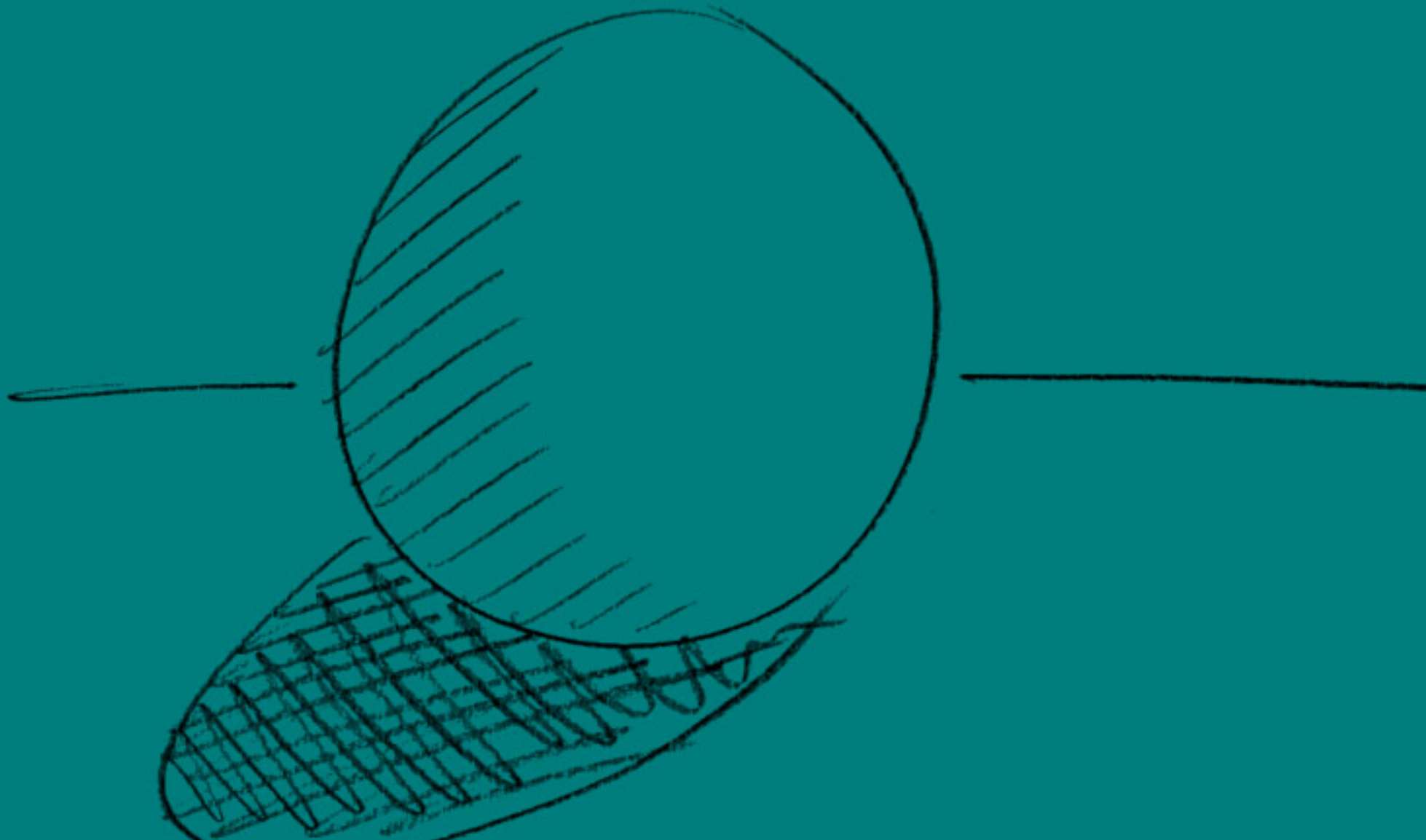

Department of Mechanical Engineering · University of Applied Sciences · Emden

Gernot
Hoffmann

What is
Computer
Vision
?

May 2003

◀ 1 ▶

Contents

Contents

1	Introduction	3
2	Basic transformations	
	Workstation transformations	4
	2D transformations	5
	3D transformations	6
3	Projections	7
4	Photogrammetry	
	Video motography	8
	Dancing marionette	9
5	Color systems	
	RGB / HLS / CieLab	10
	CIE chromaticity	11
6	Color management	
	Consistent colors	12
	CMS workflow	13
	Monitor calibration	14
	Printer calibration	15
7	Image processing	
	Geometry / interpolation	16
	Geometry / morphing	17
	Light effects	18
	Filtering	19
8	Computer graphics	
	Wireframes / rendering	20
	Textures	21
9	3D-Scanning	
	Our scanner	22
	Scanning the Hagia Sophia	23
10	PostScript workflow	24
11	Acknowledgement	25
12	Last page	26

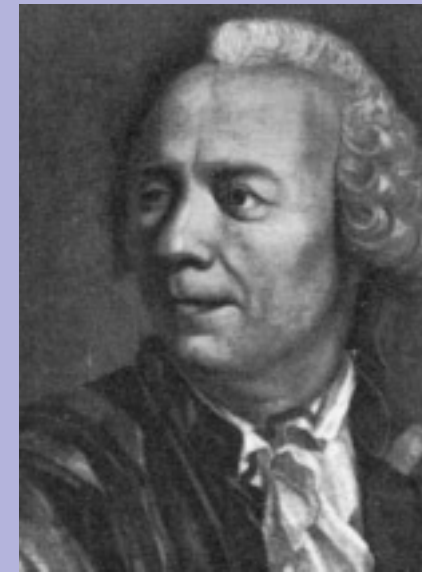

Leonhard Euler
1707 - 1783

Best View

Zoom = 100%

Ctrl + 1

Menue Bars Off

F8 / F9

Gernot
Hoffmann

What is
Computer
Vision
?

May 2003

◀ 2 ▶

Contents

1 Introduction

What is Computer Vision ?

A science - and a lecture by the author

The lecture was initiated by an attempt to describe computer graphics and photogrammetry by the same mathematical nomenclature

Color handling gained more and more importance

Writing down the lecture, it turned out that advanced Paper and Web publishing programs were necessary

Finally, the lecture Computer Vision contains geometry mathematics, image processing, computer graphics, photogrammetry, color science and media techniques

CV is not a lecture about commercial programs, though we refer often to Photoshop and PageMaker

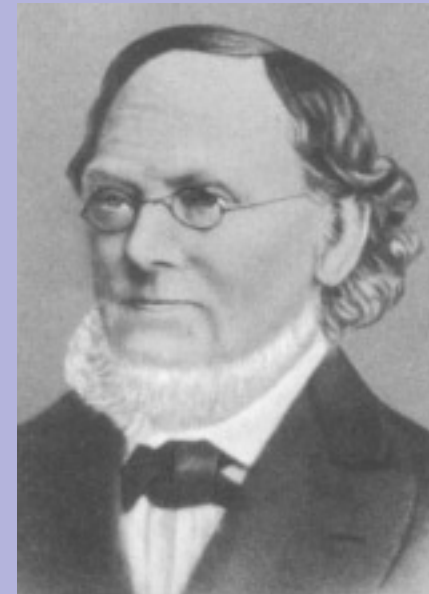

Hermann
Graßmann
1809 - 1877

This doc contains
the illustrations
for an introduction
into
Computer Vision

Gernot
Hoffmann

What is
Computer
Vision
?

May 2003

◀ 3 ▶

Contents

2 Basic Transformations / Workstation 2D-Transformation

Graphics Elements in a
metaplane

Any set of coordinates

Source area by Frame

Graphics Elements in a Device
Printer, monitor or page

Device specific coordinates

Destination area by Viewport

$$x_v = x_{va} + (x_f - x_{fa}) \frac{x_{ve} - x_{va}}{x_{fe} - x_{fa}}$$

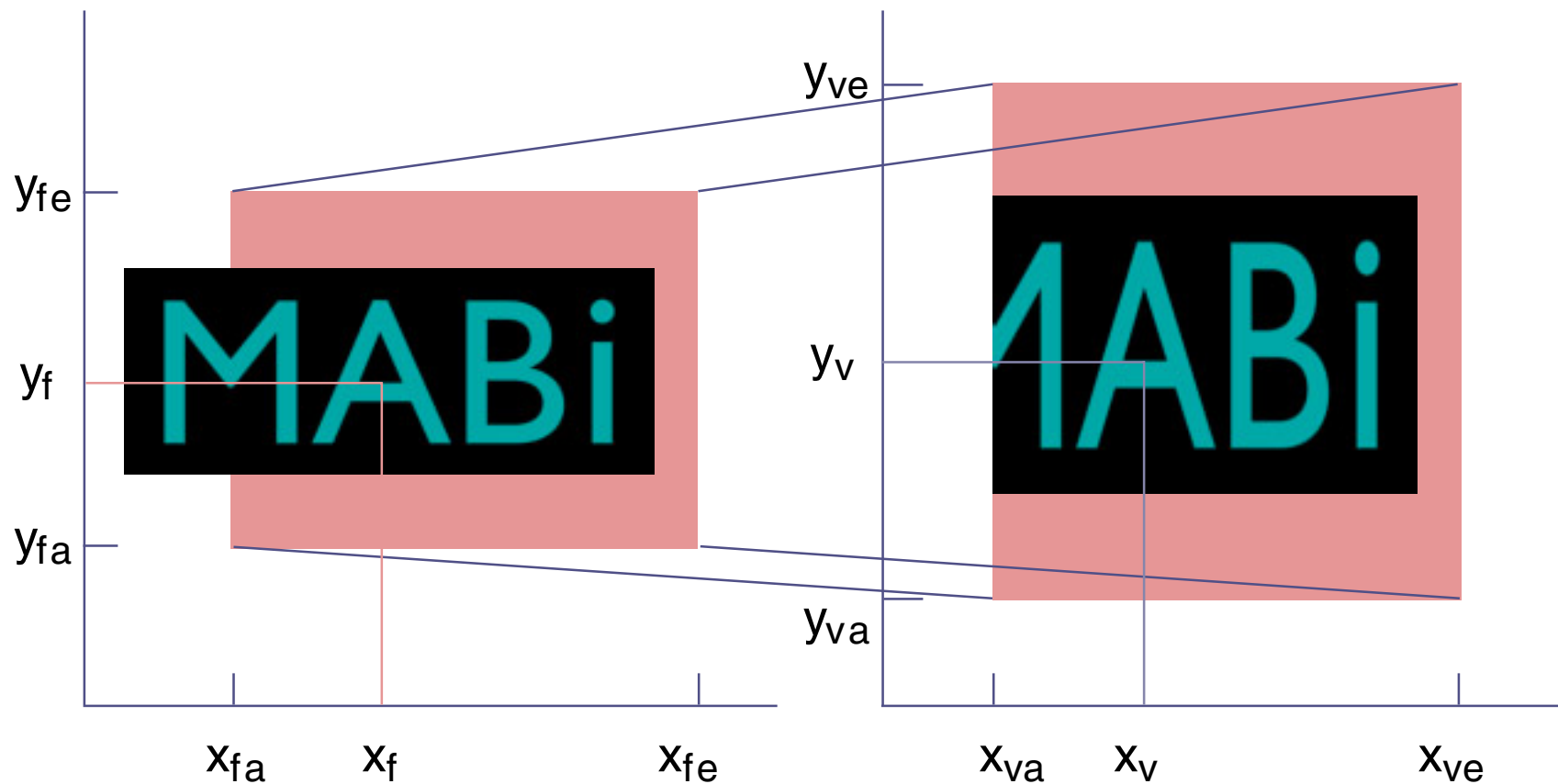

Gernot
Hoffmann

What is
Computer
Vision
?

May 2003

◀ 4 ▶

Contents

2 Basic Transformations / 3D-Transformation / Rotation

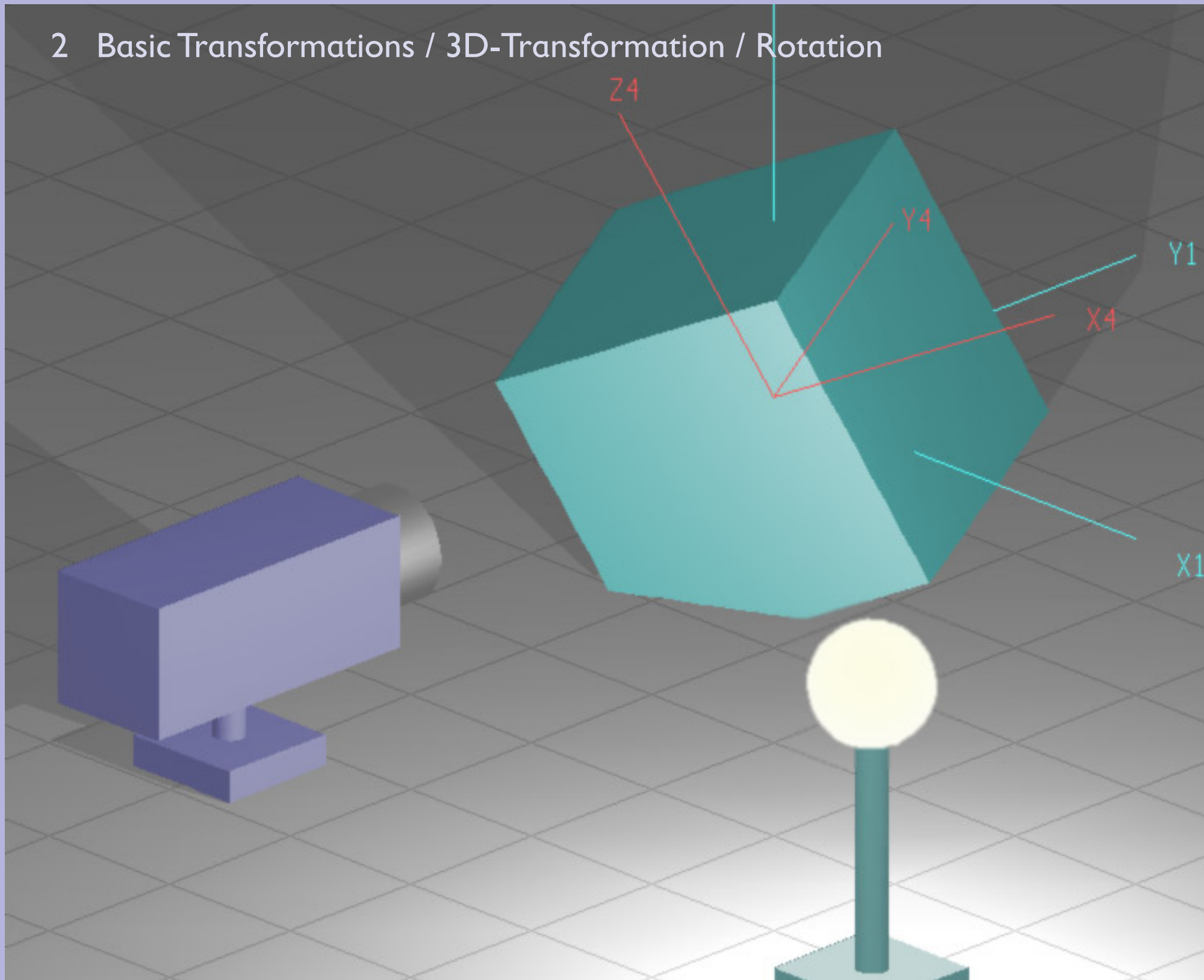

Gernot
Hoffmann

What is
Computer
Vision
?

May 2003

◀ 6 ▶

Contents

3 Projections for Computer Graphics

Isometric by camera position at infinity, a mathematical construct

Normal by natural camera position, perspective projection

Rectified by natural camera position and tilted image plane

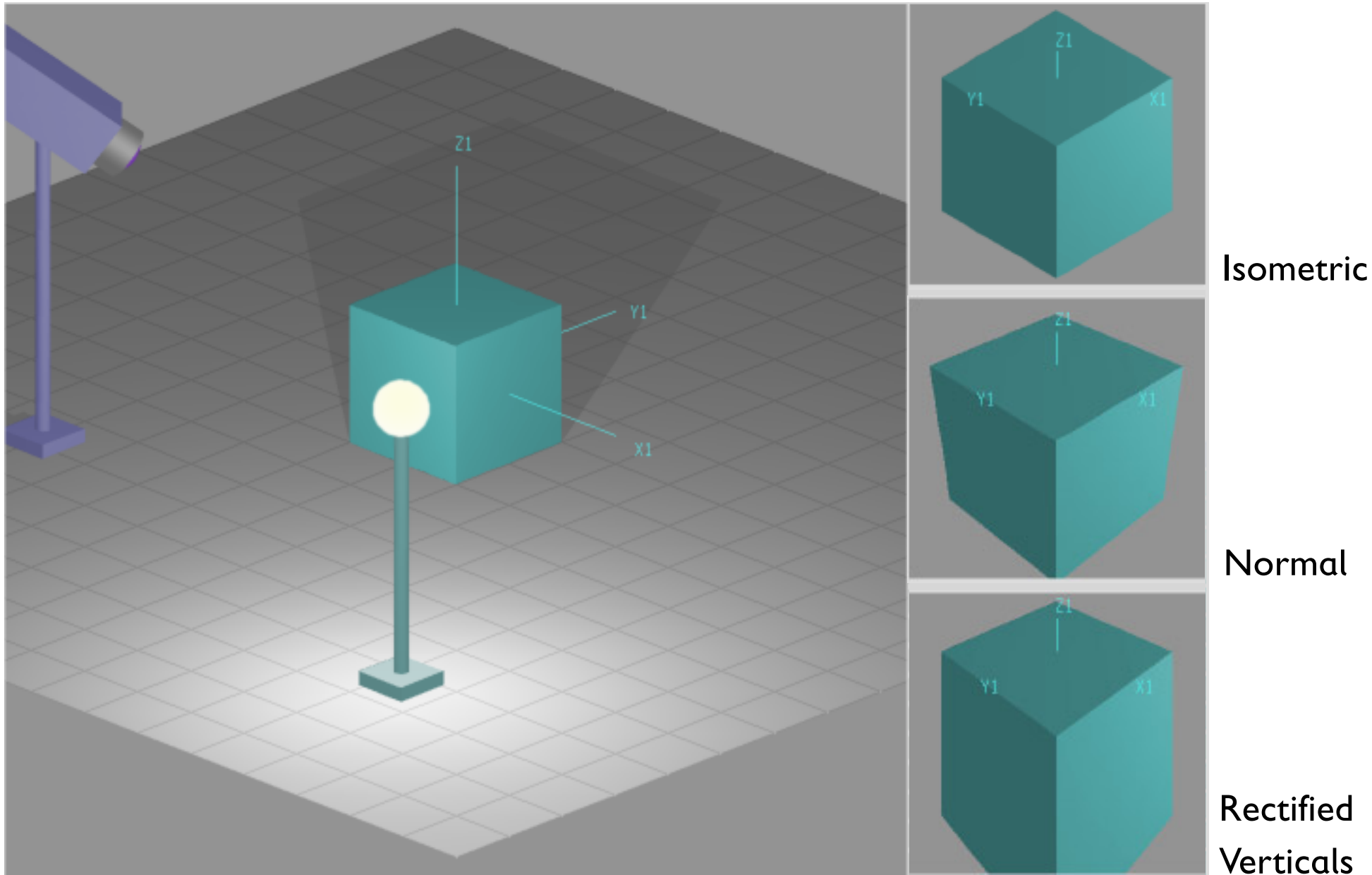

Gernot Hoffmann

What is Computer Vision ?

May 2003

◀ 7 ▶

Contents

4 Photogrammetry / Video Motography

Observe four light emitting diodes by two video cameras

Calculate LED positions by photogrammetry

Copy human dancing motions to a computerized life size marionette

Teaching a robot by showing the motion

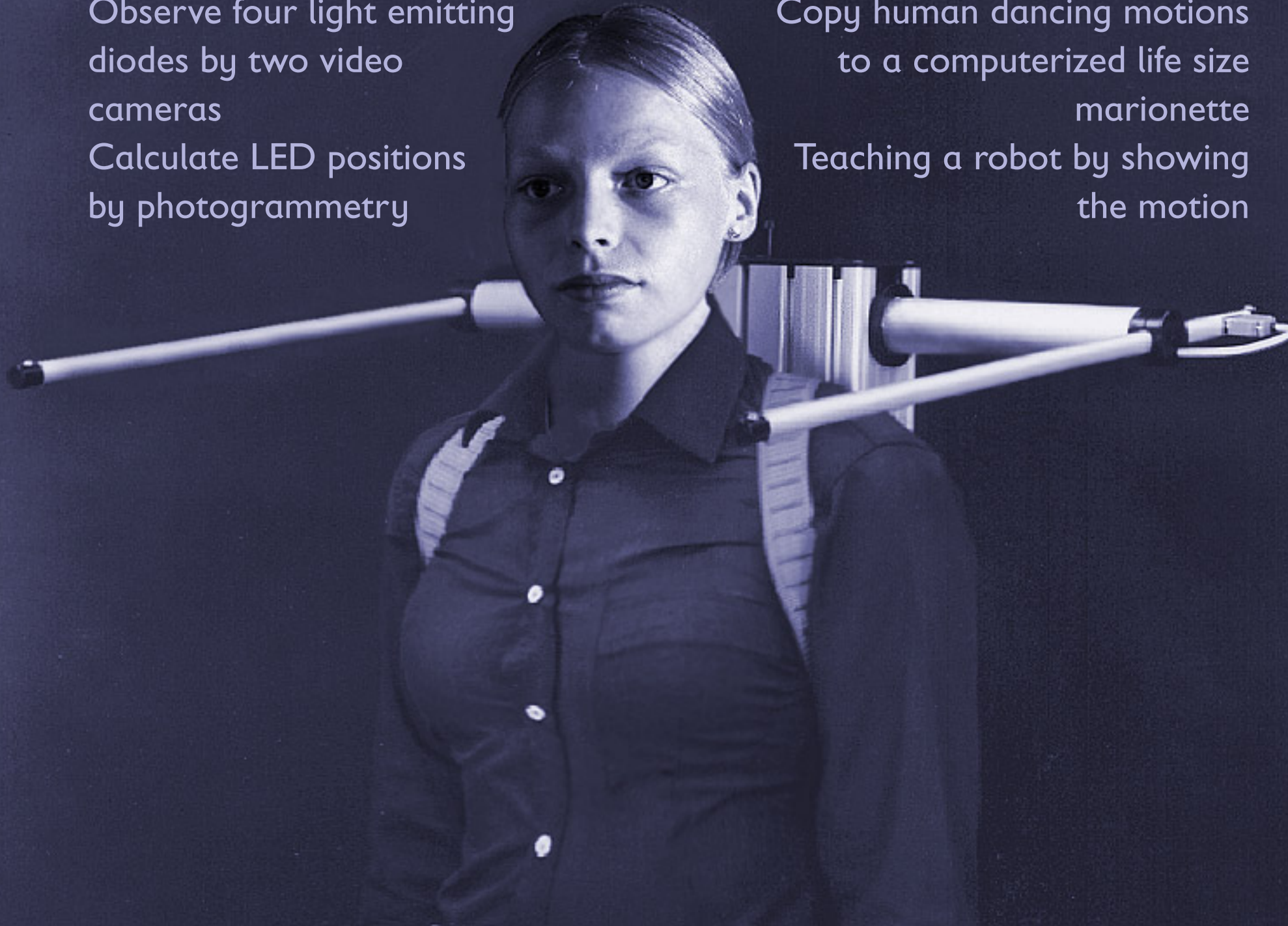

Gernot Hoffmann

What is Computer Vision ?

May 2003

◀ 8 ▶

Contents

4 Photogrammetry / Laboratory with Calibration Targets / Marionette

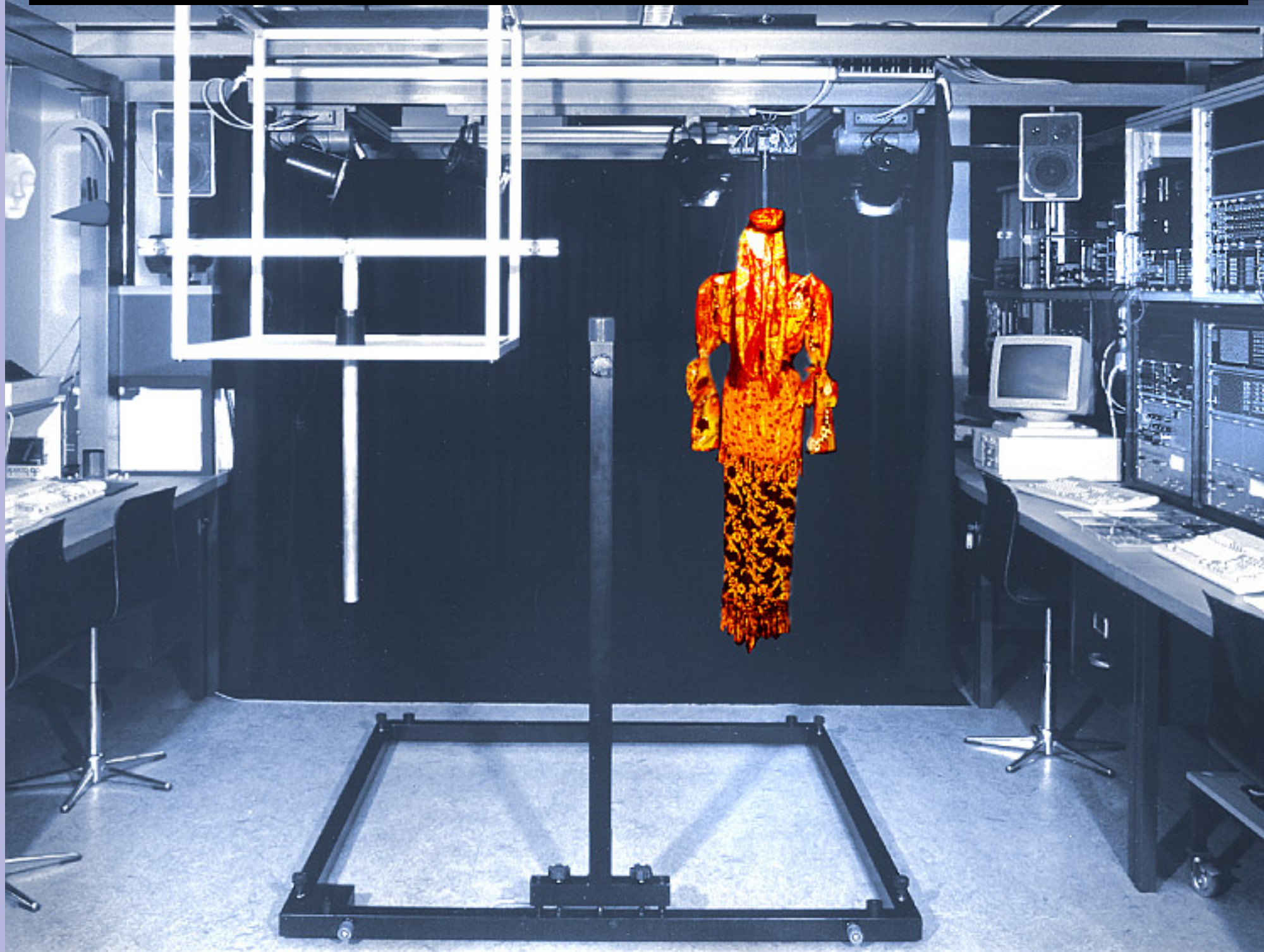

Gernot
Hoffmann

What is
Computer
Vision
?

May 2003

◀ 9 ▶

Contents

5 Color Systems / RGB Cube / HLS Doublecone / Physical CIELab Space

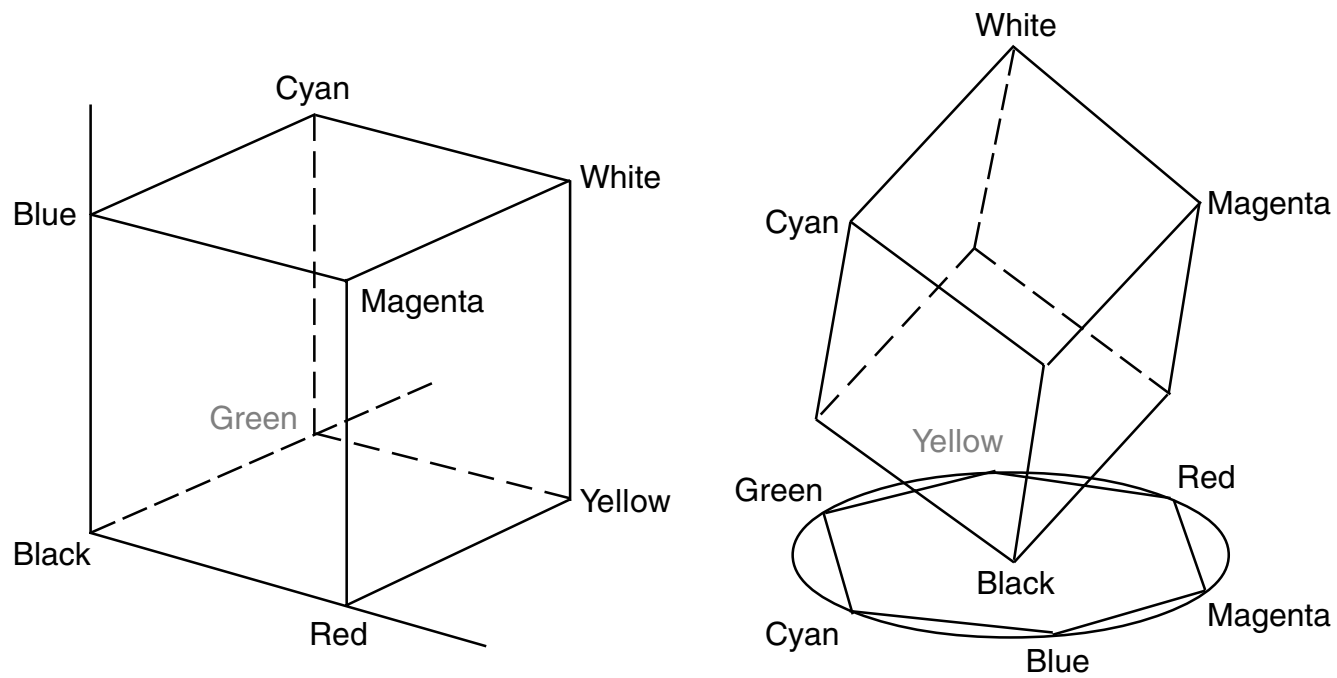

RGB Cube

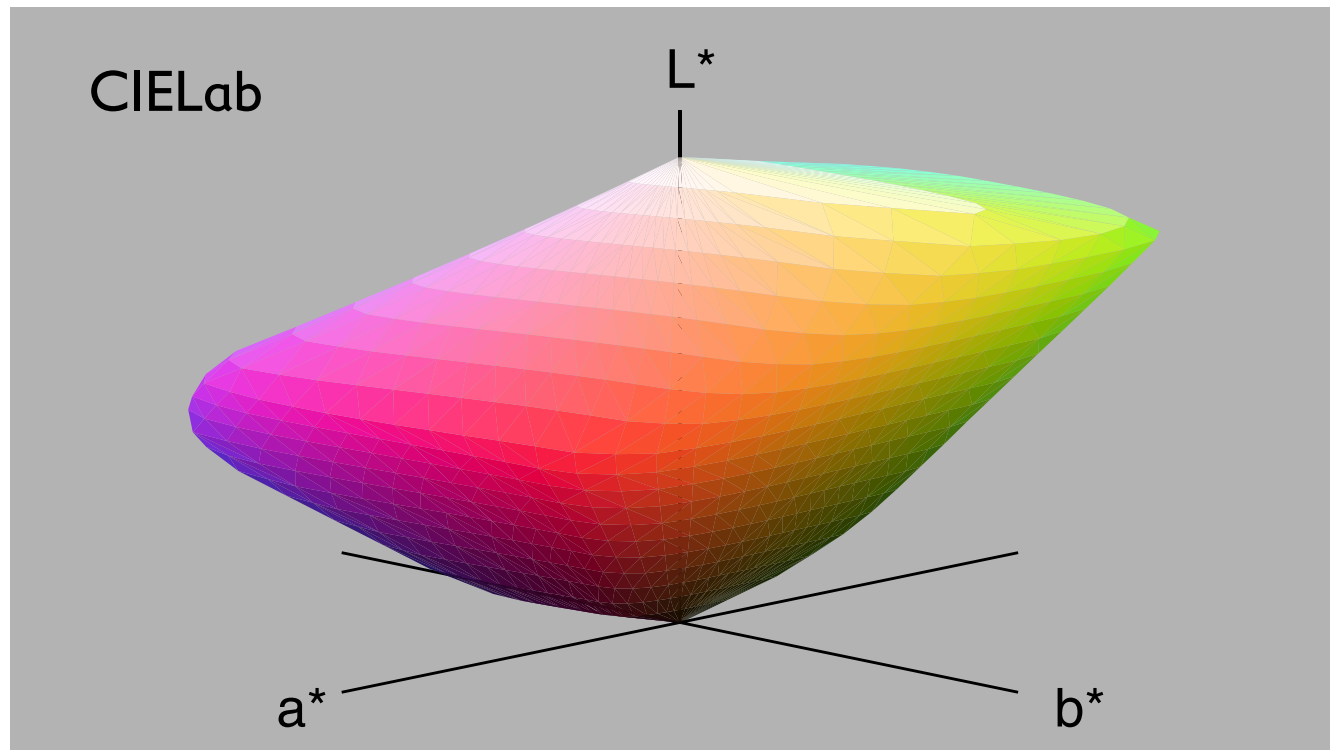
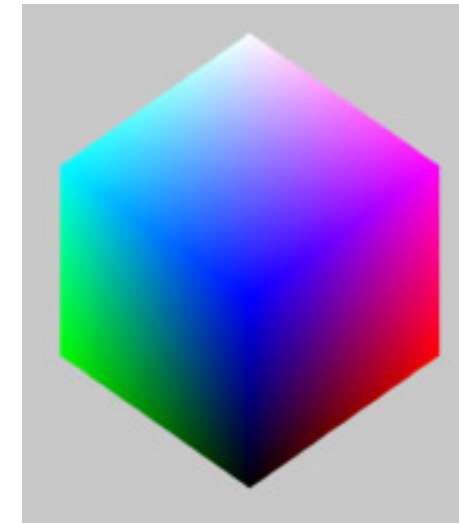

Hue / Lightness / Saturation Cone

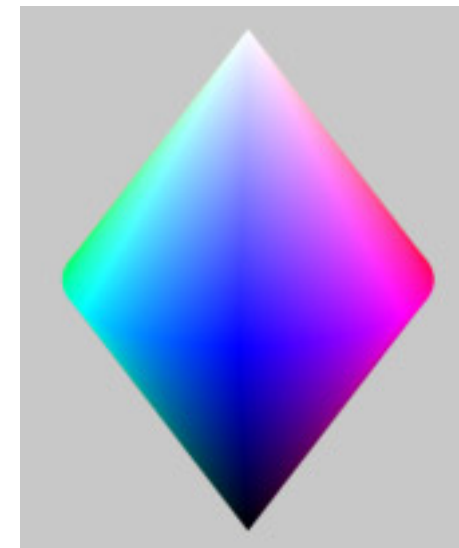

Gernot Hoffmann

What is Computer Vision ?

May 2003

◀ 10 ▶

Contents

5 Color Systems / CIE Chromaticity Diagram

Illustration of visible colors in a plane x,y
RGB gamuts are represented by triangles

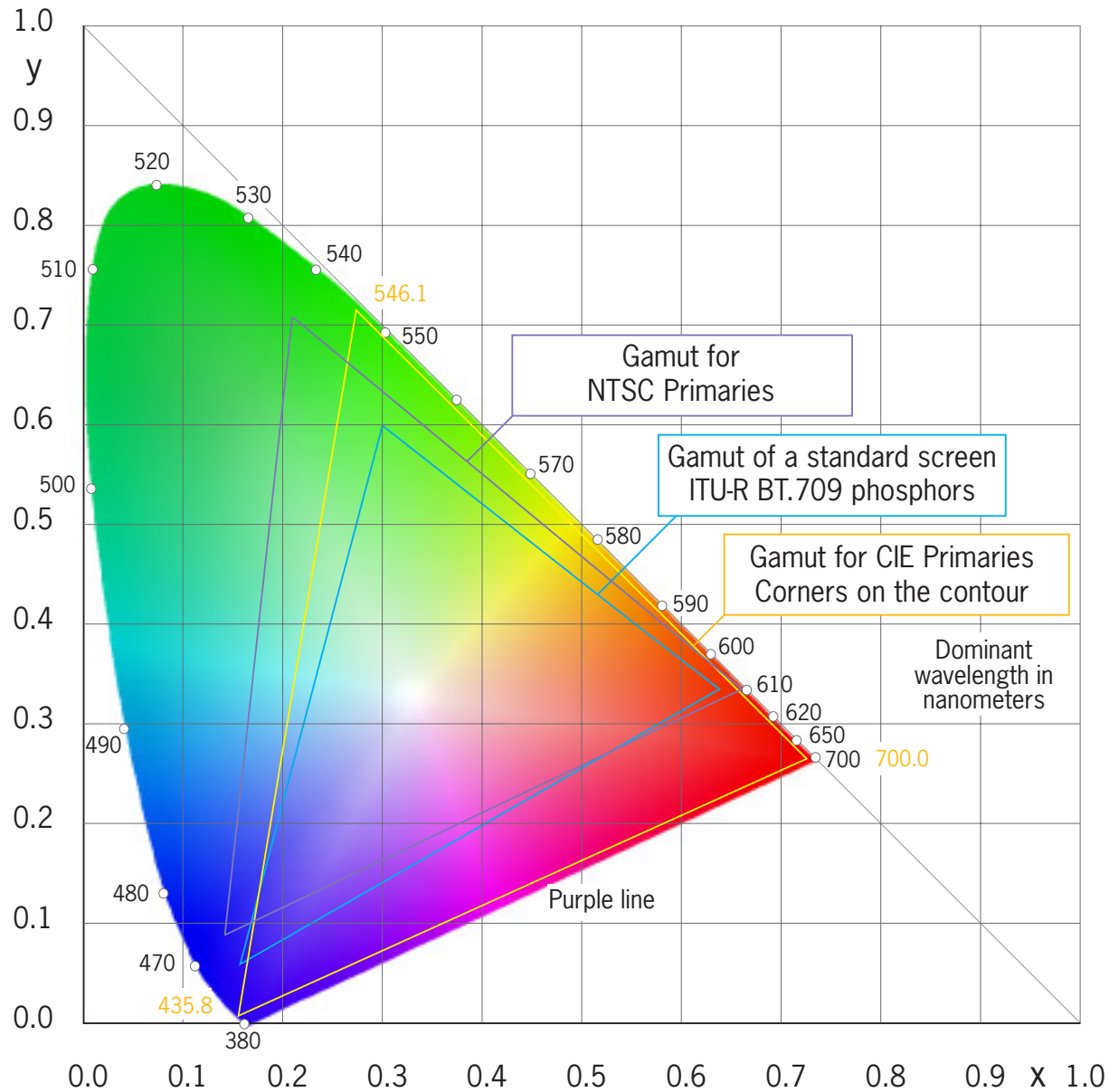

Volume of visible colors in
XYZ coordinates

Based on color matching
principles by H.Graßmann

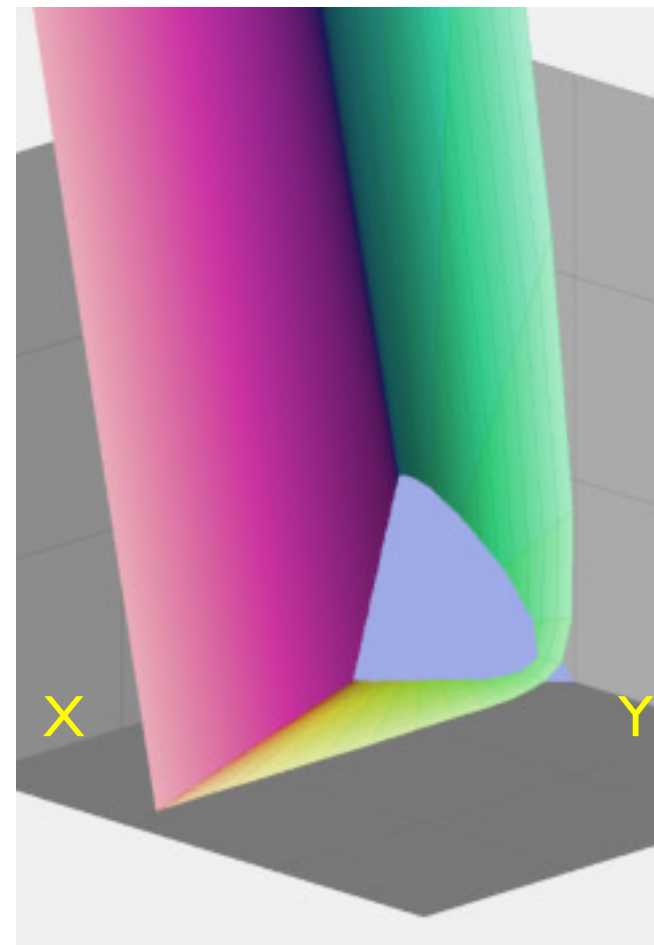

Gernot
Hoffmann

What is
Computer
Vision
?

May 2003

◀ 11 ▶

Contents

6 Color Management / Consistent Colors in Product Development

Graphics Products

Poster
Brochure
Book

Package

Web information

Traffic information

Industrial Products

Traffic Car / Bike / Van / Boat / Train / Aircraft
House Kitchen / Garden / Bathroom / Tiles /
Furniture / Textile / Table-ware
Fashion Cloth / Shoes / Jewelery
Sports Equipment / Fashion
Food Drink / Food
Tech Audio / TV / Video / Watch / Camera
Industry Tool machine / Robot / Transport
Medical X-Ray / Dental equipment / Ultrasonic

Swatch Books

CMYK
HKS
Pantone Spot / Process
Hexachrome / Metallic
Pantone Film / Foil

Sample Collections

RAL
Textile / Carpet / Tiles

Pantone Plastic
Pantone Textile

Integrate swatches and samples into a computer controlled workflow
Colors are measurable by instruments - but perception is subjective

Gernot
Hoffmann

What is
Computer
Vision
?

May 2003

◀ 12 ▶

Contents

6 Color Management / Workflow

Calibrate Monitor

- by Hardware
- by Adobe Gamma
- by Instrument

Calibrate Printer

- by Instrument

Define Working Space

Optimize Images by appearance on monitor

Result

Working Space RGB-Data which refer accurately to physical colors

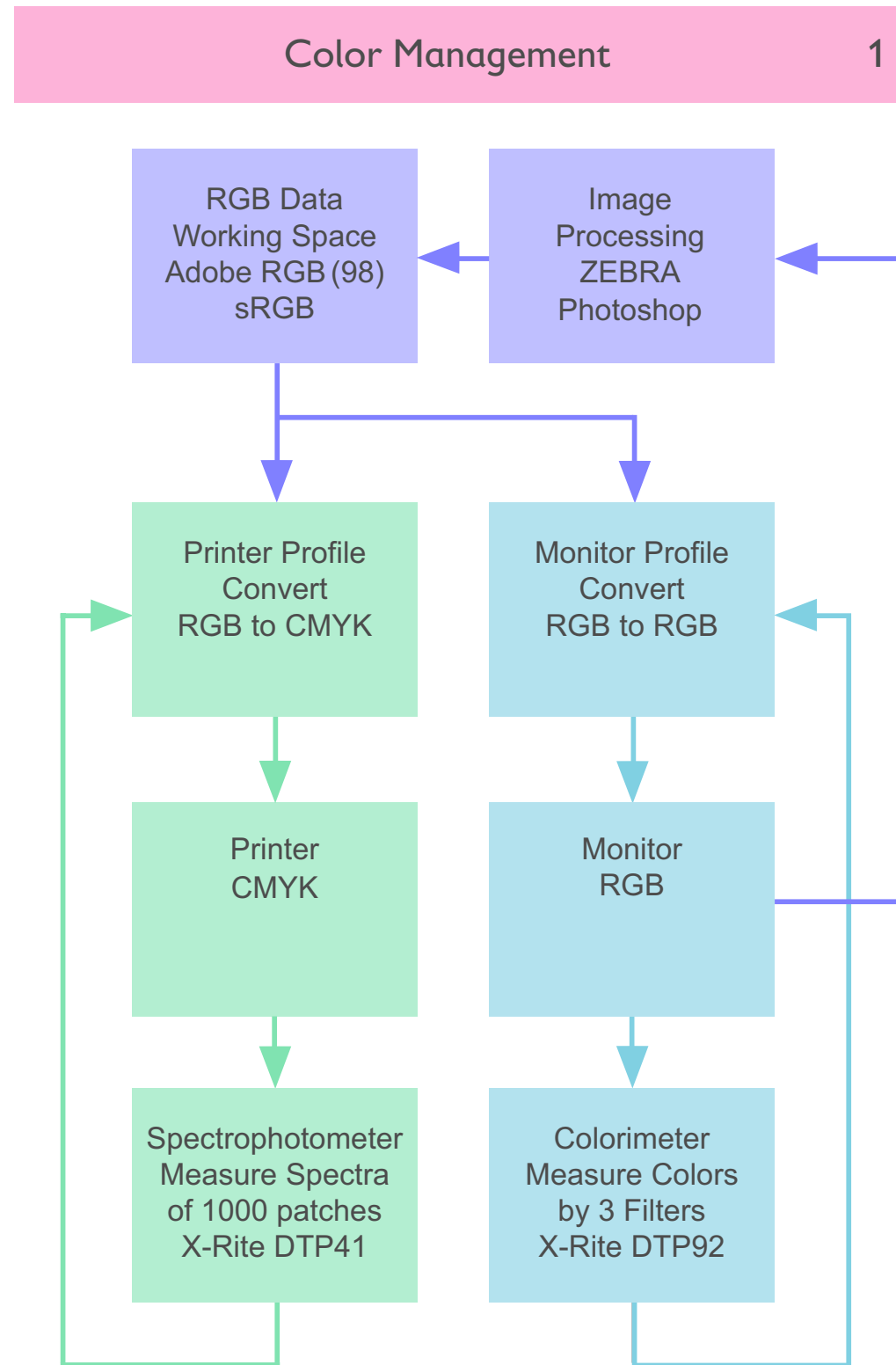

Gernot Hoffmann

What is Computer Vision ?

May 2003

◀ 13 ▶

Contents

6 Color Management / Monitor Calibration

Web document caltutor270900.pdf / Adjust your monitor

Hardware Monitor Calibration

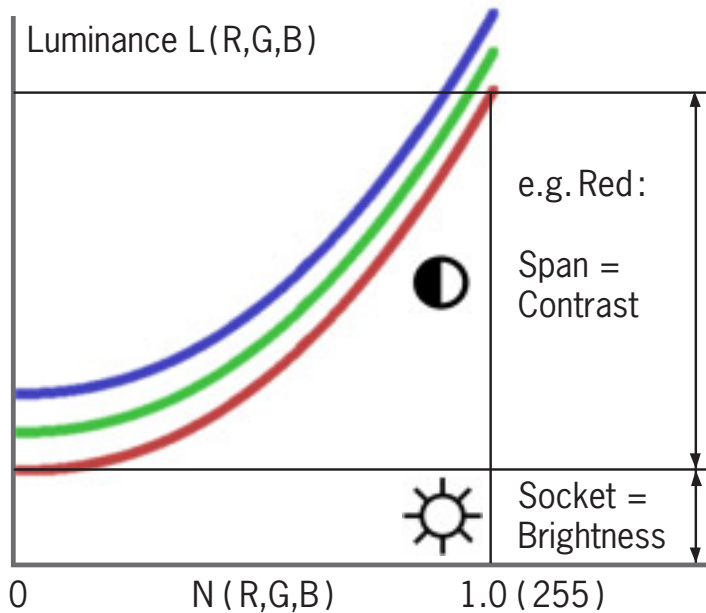

$$\text{Luminance} = (\text{Brightness} + \text{Contrast} \cdot N)^{\text{Gamma}}$$

- 1 Let your monitor warm up one hour
- 2 Adjust Contrast to maximum
- 3 Adjust Brightness for Black
Brightness is not used for White
A black rectangle should be visible (arrow)
- 4 Adjust Contrast for White luminance
- 5 Try to balance all colors until the Grayscale shows no tint of any color
- 6 Shift to red gray: Standard D65 6500 K
Shift to blue gray: Standard Monitor 9300 K

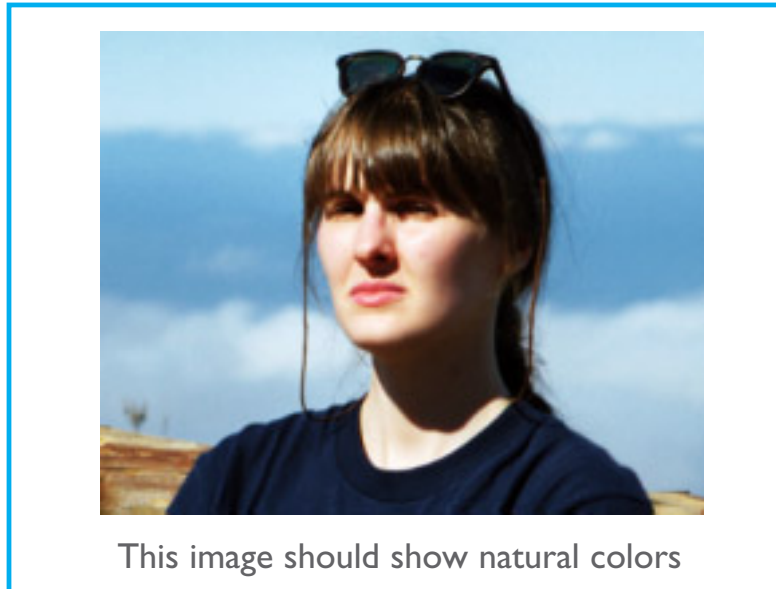
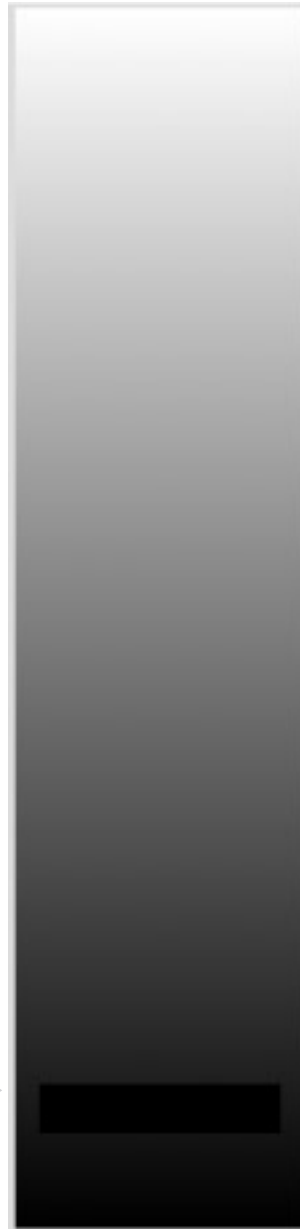

Gamma Test Patterns

2.0 2.2 2.4

Equal Gray for inner and outer square
Adjust Gamma = 2.2

Use Zoom 100% or 200%
Browsers are not accurate
Please download and view by Acrobat

3

Gernot Hoffmann

What is Computer Vision ?

May 2003

Best View
Monitor G=2.2

Zoom = 100%
Ctrl +1

Menu Bars Off
F8 / F9

◀ 14 ▶

Contents

6 Color Management / Printer Calibration

Print about 1000 color patches

Read patches by Spectrophotometer

Build color correction table /ICC Profile

Result: print is as accurate as possible



ICC Profiles are valid only for a specified process

- Printing machine
- Actual ink cartridges
- Paper or other media
- Resolution
- Dithering mode
- Ink limit setting
- Dark/light ink transition
- Undercolor removal
- Rendering Intent

High quality printing programs are called Raster Image Processors (RIPs)
We use Onyx PosterShop Pro and Best Colorproof

7 Image Processing / Geometry / Interpolation

Rotation, scaling, morphing and perspective rectification require subtle interpolation algorithms

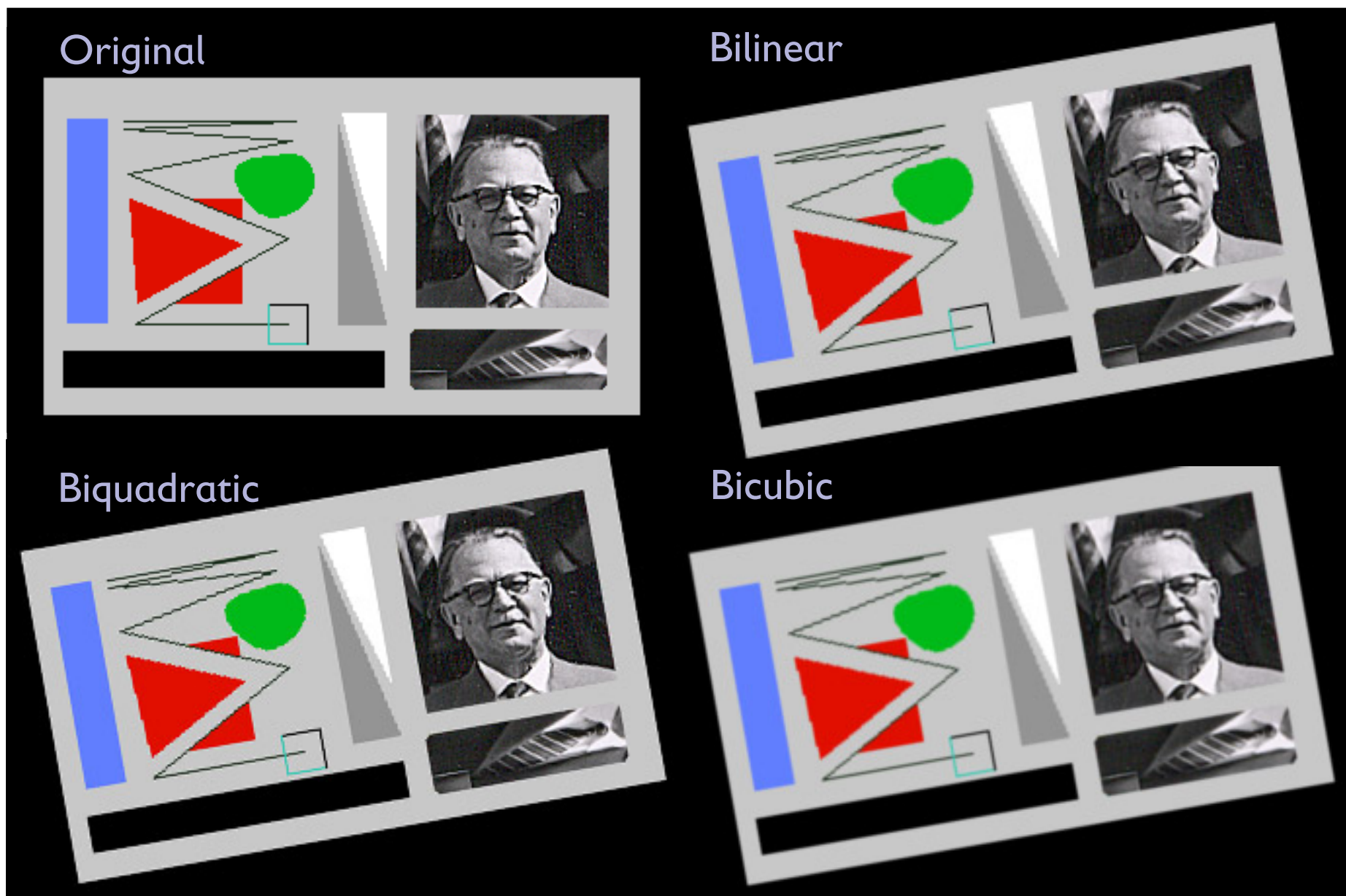

Gernot
Hoffmann

What is
Computer
Vision
?

May 2003

◀ 16 ▶

Contents

7 Image Processing / Geometry / Morphing

Perspective rectification

Four lines, one mouse click



Morphing

Circle shows affected area



Gernot
Hoffmann

What is
Computer
Vision
?

May 2003

◀ 17 ▶

Contents

7 Image Processing / Light Effects

Light effects by simulating the illumination of a paper photo by lamps

Artificial color illumination for the glass sphere and the blue cube



Darker environment and soft white light



Gernot
Hoffmann

What is
Computer
Vision
?

May 2003

◀ 18 ▶

Contents

7 Image Processing / Filtering

Retouch

Sharpening

Sky segmentation



Contour

Sometimes used internally for
edge enhancement or softening

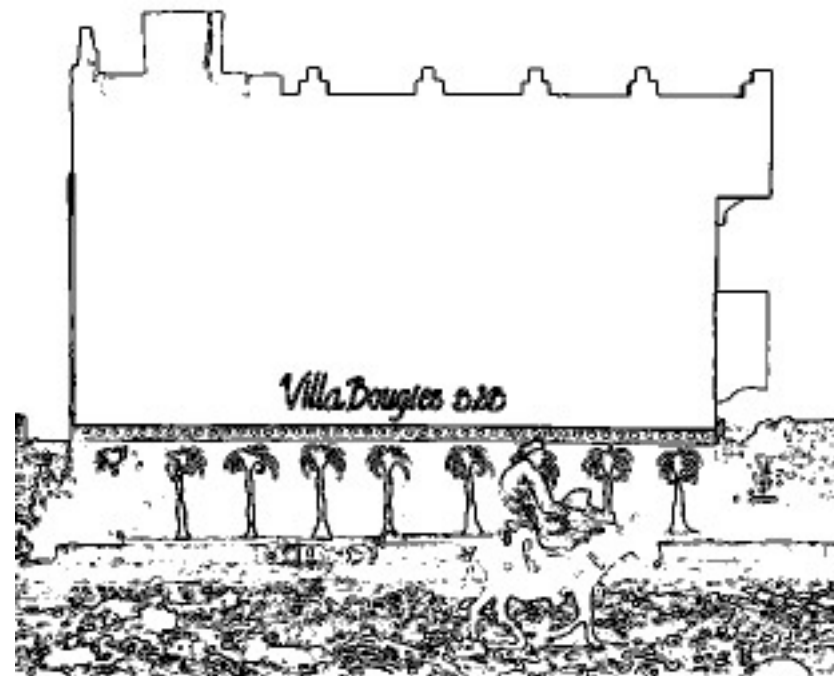

Gernot
Hoffmann

What is
Computer
Vision
?

May 2003

◀ 19 ▶

Contents

7 Computer Graphics / Wireframes / Rendering

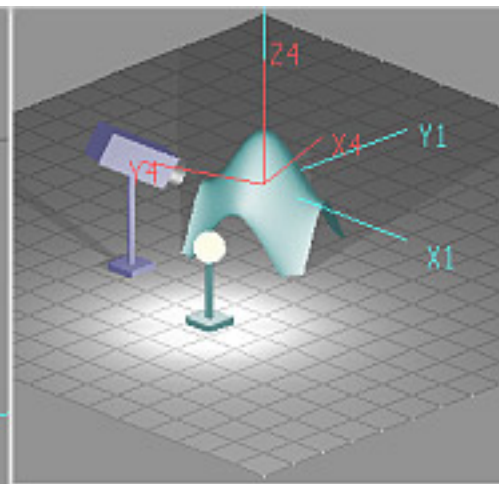
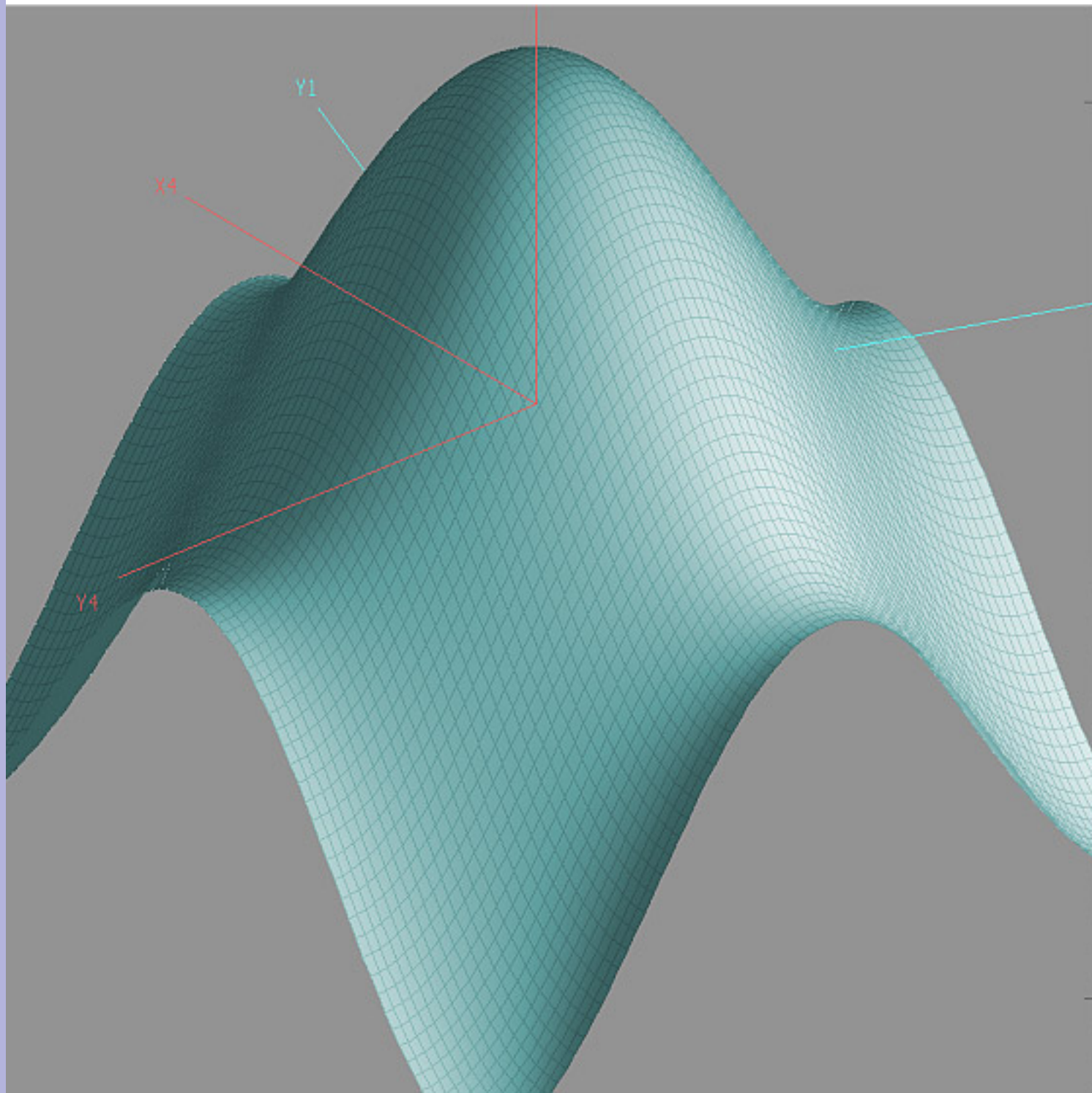

- ZEFIR Aug.12 2001
- View in large Window
- Internal/External Camera
- S Swap Int/Ext = Int
- Parameters
- I Internal Camera + Light
- E External Camera + Light
- O Object Type +Rotate+Col
- T Texture Image+Adjust+Mix
- D Default
- Operation
- R Read many Textures
- W Write Graphics to Disk
- Alt+FB SnapShot
- Ctrl+Q Quit

Gernot Hoffmann

What is Computer Vision ?

May 2003

◀ 20 ▶

Contents

8 Computer Graphics / Textures

Subdivided icosahedron
Single icon mapping
Facetted shading



Subdivided icosahedron
Multiple icon mapping
Gouraud shading

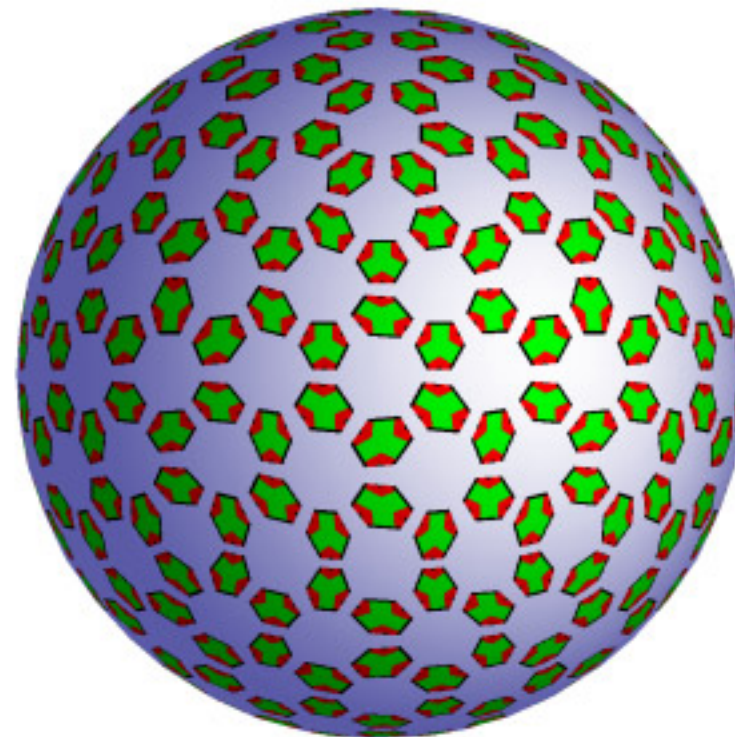

Gernot
Hoffmann

What is
Computer
Vision
?

May 2003

◀ 21 ▶

Contents

9 3D-Scanning

Our scanner

Turntable and lift

Range by triangulation, using a single row CCD camera

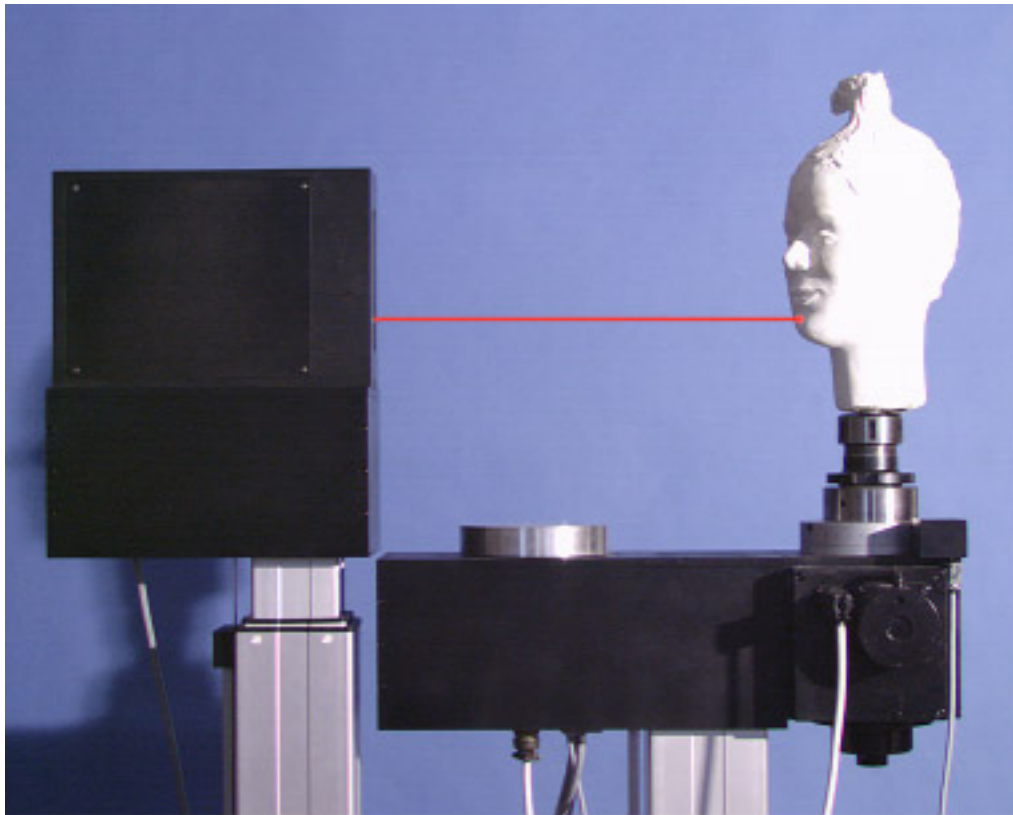

Scanner construction by Toni Gosling

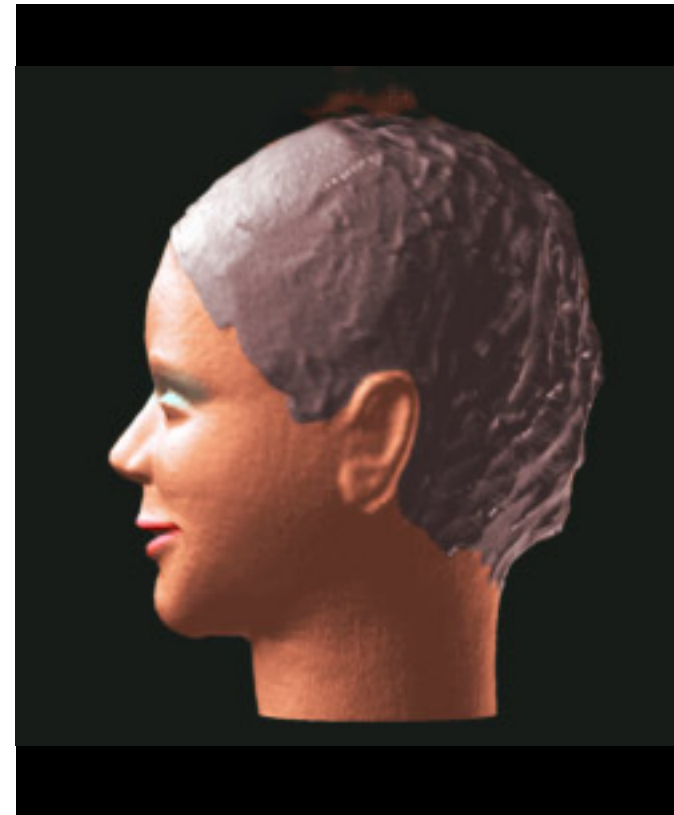

Graphics by ZEFIR

Gernot
Hoffmann

What is
Computer
Vision
?

May 2003

◀ 22 ▶

Contents

9 3D-Scanning

Industrial scanner Cyrax 2500

Scanning the Hagia Sophia

A project by Prof. Dr. Volker Hoffmann

Institute for History of Art / University of Bern / Switzerland



Hagia Sophia in Istanbul
Church / Mosque / Museum
Built 532-537



Laser beam deflection
by two-axis mirror
Range by light runtime

Gernot
Hoffmann

What is
Computer
Vision
?

May 2003

◀ 23 ▶

Contents

10 PostScript Workflow

PostScript is a page description language

A page consists of

- Vector graphics: lines / boxes / curves / circles
- Text: a special kind of vector graphics
- Raster graphics: photos or computer graphics

PostScript guarantees

Consistent workflow between desktop publishing programs PageMaker / InDesign / Quark XPress and printers

PostScript printers

Receive all necessary data for a page

Build the page by an internal high speed processor

Calculate the CMYK color pixels for the printing

Use PostScript PDF for documents

Use PostScript EPS for single pages

Use BMP or TIFF for single raster images



Sir Isaac Newton
1643 - 1717

Gernot
Hoffmann

What is
Computer
Vision
?

May 2003

◀ 24 ▶

Contents

11 Acknowledgement

Many students contributed to the marionette project
Thanks also to Wilhelm Kettwig, member of the staff

Image Processing system ZEBRA	Ralph Scherge Author
JPEG compression module	H. Hildebrandt Author
Computer Graphics system ZEFIR	W.Kettwig (8, 9) R.Scherge (14,17) Author
Photos	
Sculpture (18) and plaster head	M.Hoffmann
Euler / Graßmann / Gauß / Newton	Reidt-Wolff



Carl Friedrich
Gauß
1777 - 1855

PDF document composed by PageMaker 6.52 and Acrobat Distiller 5.05

PostScript / PageMaker / InDesign / Acrobat / Photoshop are trademarks
of Adobe Systems Inc.

Gernot Hoffmann
May 20, 2002 / May 08, 2003

Website
Load browser / Click here

Gernot
Hoffmann

What is
Computer
Vision
?

May 2003

◀ 25 ▶

Contents

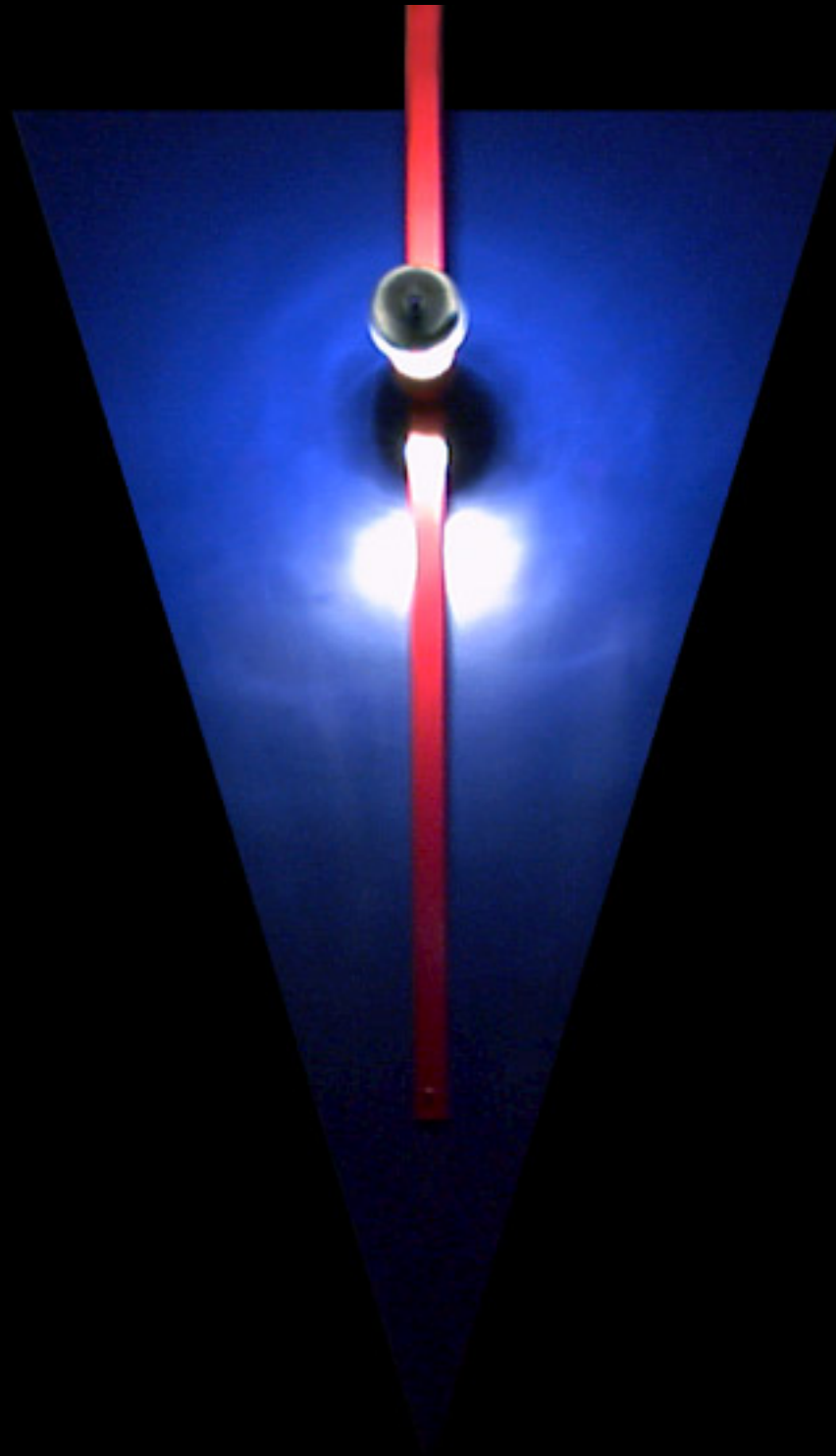

Computer Vision